



VRLA Rechargeable Battery

EVP70-12 (EVP70-12FR)



FEATURES

- Absorbent Glass Mat technology for efficient gas recombination
- Maintenance free(no water topping-up required)
- No free acid(Non-spillable battery)
- Low self-discharge rate, lower than 3% capacity loss per month
- Can be used in any orientation(excluding used inverted)
- The battery is designed for high power & high cyclic usage

APPLICATION

- UPS
- Wheelchairs
- Lawn Mowers
- Equipment
- Golf-Carts
- Electronic Medical Equipment



SPECIFICATIONS

Nominal Voltage	12 V
Nominal Capacity	70Ah @ 20 hour rate F.V.(1.75V/cell)
Approx. Weight	25.0Kg(55.13lbs.)
Terminals	B5 (Fitting M6 bolt & nut) I2 is optional
Internal Resistance	≤4mΩ (Fully Charged)
Max. Discharge Current	650 A (5 sec.)
Max. Charge Current	21 A
Operating Temperature Range	Charge : 0°C~40°C(32°F~104°F) Discharge : -20°C~50°C(-4°F~122°F) Storage. : -20°C~40°C(-4°F~104°F)
Container Material	ABS(UL94-HB, UL94-V0 is optional)

ISO 9001	
ISO14001	
UL	
CE	
<ul style="list-style-type: none"> ● IEC 61056-1 ● JIS C 8702-1 ● GB/T 19639.1 	

DIMENSION(mm/inch)

OUTER DIMENSIONS

TERMINAL TYPE

- **Length**
350±2.0 (13.78±0.08)
- **Width**
166±2.0 (6.54±0.08)
- **Container Height**
174±2.0 (6.85±0.08)
- **Total Height**
174±2.0 (6.85±0.08)

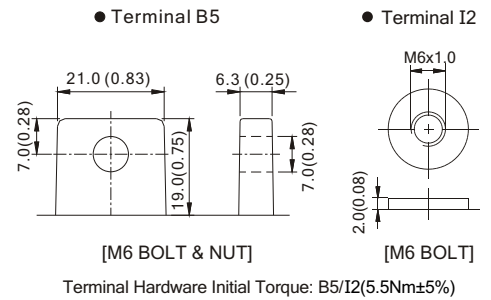
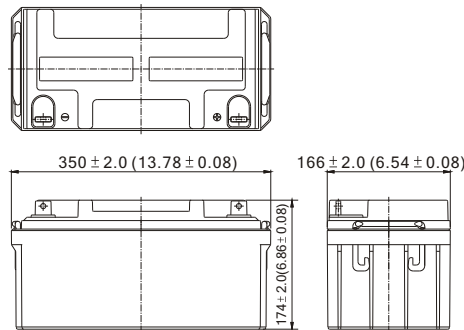

Constant power discharge characteristics at 25 °C/77 °F Unit: W

F.V. (V/cell) \ Discharge Time	15 Min	30 Min	1 Hr	3 Hr	5 Hr	10 Hr	20 Hr
1.80V	1467	944	538	223	141	78.4	41.1
1.75V	1541	979	554	228	143	80.0	42.0
1.70V	1585	1001	566	230	144	80.5	42.2
1.65V	1622	1016	572	232	145	80.7	42.3
1.60V	1651	1029	577	233	145	80.7	42.3

Constant current discharge characteristics at 25 °C/77 °F Unit: A

F.V. (V/cell) \ Discharge Time	15 Min	30 Min	1 Hr	3 Hr	5 Hr	10 Hr	20 Hr
1.80V	132.12	83.48	45.20	18.56	11.73	6.54	3.43
1.75V	140.03	86.65	46.51	19.03	11.93	6.67	3.50
1.70V	144.12	88.58	47.56	19.17	12.03	6.71	3.52
1.65V	147.40	89.95	48.08	19.36	12.08	6.72	3.53
1.60V	150.04	91.06	48.48	19.42	12.12	6.72	3.53

All data shall be changed without prior notice, BB reserves the right to explain and update the information contained hereinto.